

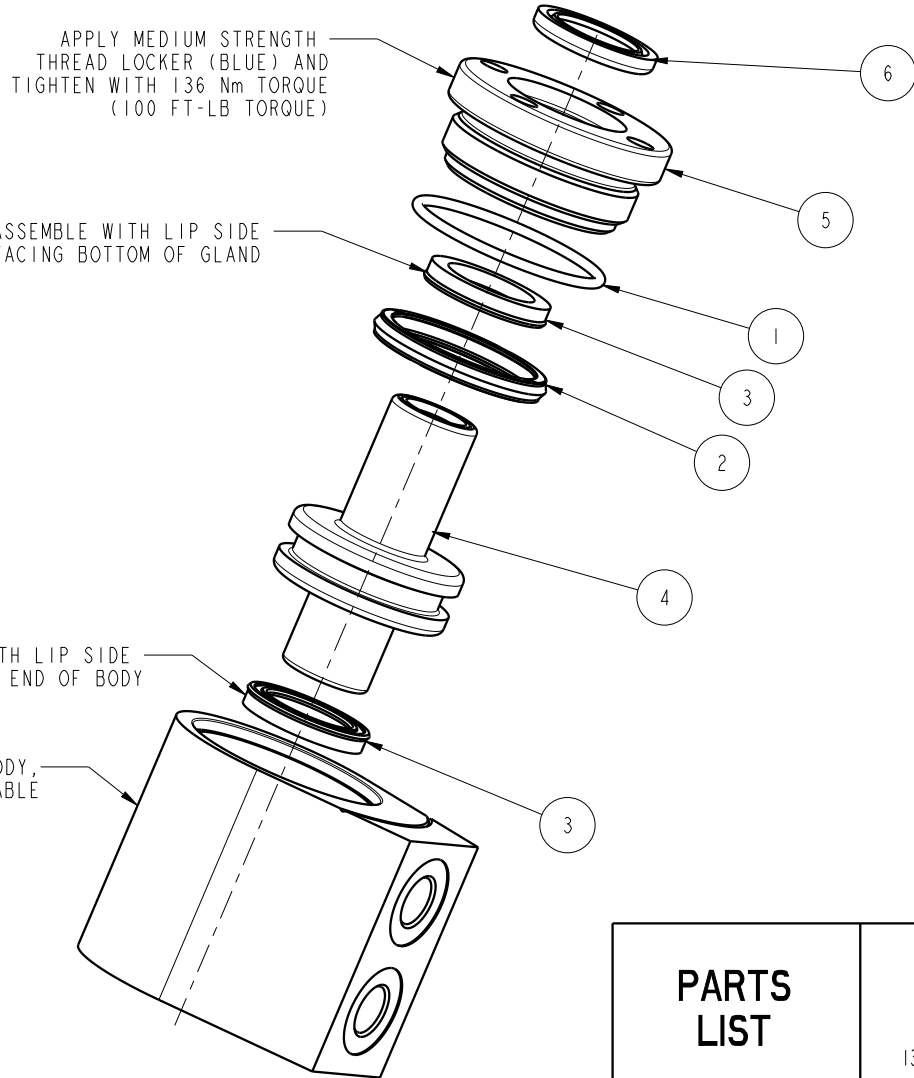

NO	QTY	PART NO	DESCRIPTION	STD SEAL KIT	FKM SEAL KIT
1	1	39001012	O-RING, (-026)	X	39V01012
2	1	39011030	SEAL,CROWN,1-1/16x1-1/4x5/32	X	39V11030
3	2	39052036	SEAL, LL, (5/8 X 1/8 X 1/8 X 7/8)	X	39V10020
4	1	48011300	PISTON, CYL, HR, 20.6 KN		
5	1	82031302	GLAND, CYL, HR, 4600&20.6KN, DA		
6	1	39V11020	WIPER,PRESS-IN, (5/8)	X	X
N/A	N/A	46000041/96396	KIT, SEAL	NOTED	N/A
N/A	N/A	6V202213	KIT, SEAL, FKM	N/A	NOTED

Lubricate seals with clean hydraulic oil prior to assembly.
DO NOT USE SILICONE BASED LUBRICANTS



PARTS LIST	 VEKTEK VEKTEK, INC. 1334 E. SIXTH AVE. P.O. BOX 625 EMPORIA, KS. 66801 U.S.A.
	ASSEMBLIES AFFECTED 42022000 6935D-20 / 67918
PARTS LIST, ASSY, CYL, HR, 20.6KN, DA	SIZE A
DRAWING STATUS: Released PRODUCTION APPROVED FOR RELEASED STATUS ONLY	REV L

L	5358	RELEASE	RLK	6/18/24
REV	IN ACCORDANCE WITH ECN	EFFECTIVE DATE	REVISED BY	DATE
DRW BY:	BUSH	DRAWING STATUS: Released PRODUCTION APPROVED FOR RELEASED STATUS ONLY		
DATE:	12/15/94			